

Distributed OS

Hermann Härtig

Modelling

Aspects of Distributed Systems

Models

- abstract from details
- concentrate on functionality, properties, ... that are considered important for a specific system/application
- use model to analyse, prove, predict, ... system properties
- models in engineering disciplines very common, not so in CS
- we'll see many models in lecture: “Real-Time Systems”
- Objective of lecture:
understand the need for careful understanding of models
- Today: 3 areas

Models for 3 areas

- Limits of Reliability of systems made of unreliable components
- Consensus
- Open source and security → separate slides

Fault Tolerance

- Techniques how to build reliable systems from less reliable components
- Fault(Error, Failure,): synonymously used for “something goes wrong”
(more precise definitions and types of faults in SE)

Reliability:

- $R(t)$: probability for a system to survive time t

Availability:

- A : fraction of time a system works

Fault Tolerance: key ingredients

- Fault detection and confinement
- Recovery
- Repair

- Redundancy
 - information
 - time
 - structural
 - functional

Examples: RAID, Triple Modular Redundancy

John v. Neumann

Voter: single point of failure

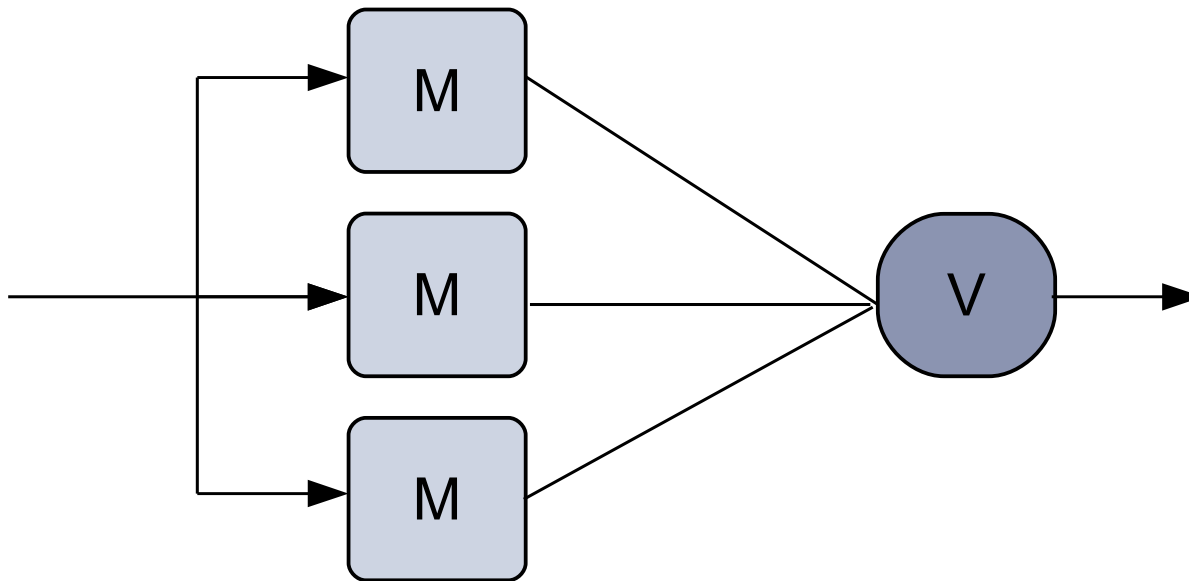

Can we do better
→ distributed solutions?

Limits(mathematical) of Reliability, Variant 1

Parallel-Serial-Systems (Pfitzmann/Härtig 1982)

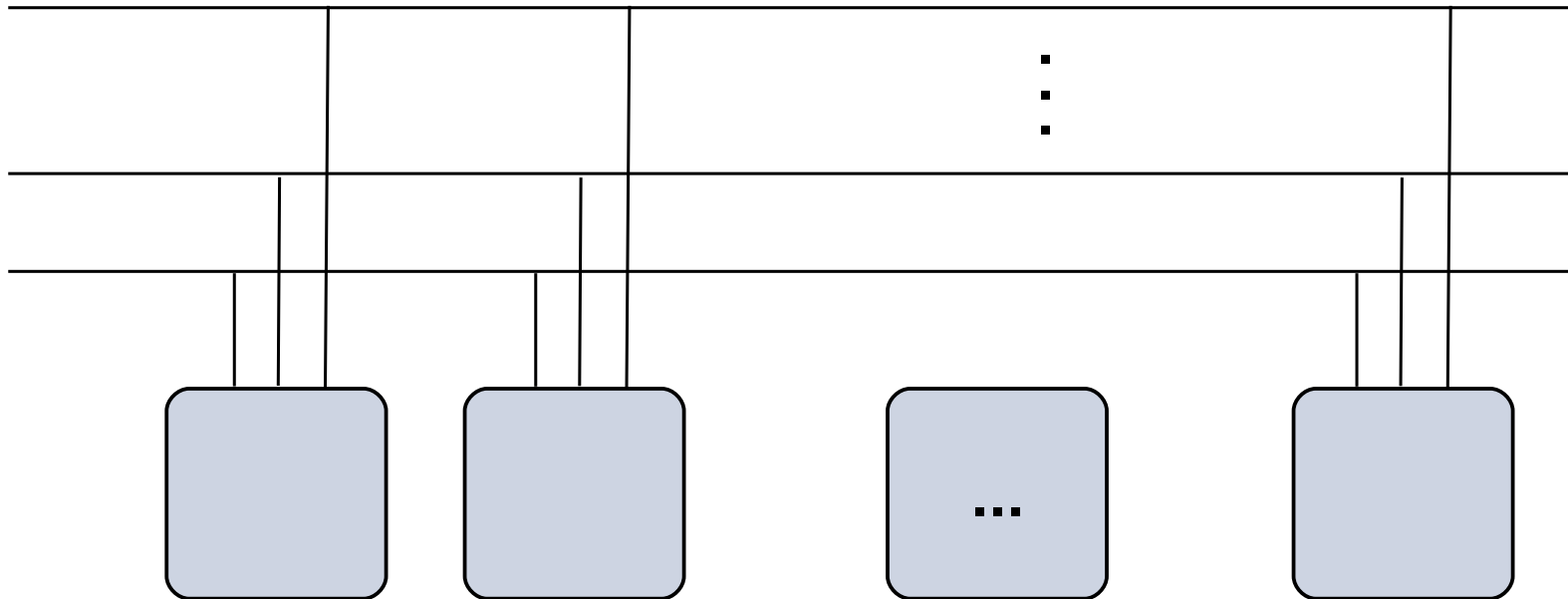

Serial Systems

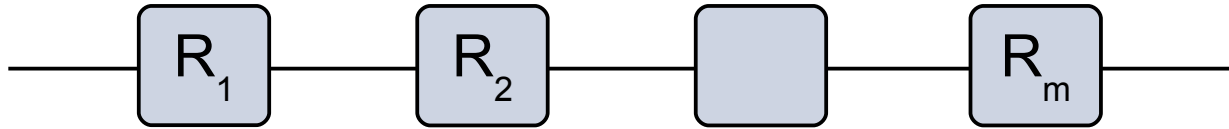

$$R_{whole} = \prod_{j=1}^n R_j$$

- Each component must work for the whole system to work.

Parallel Systems

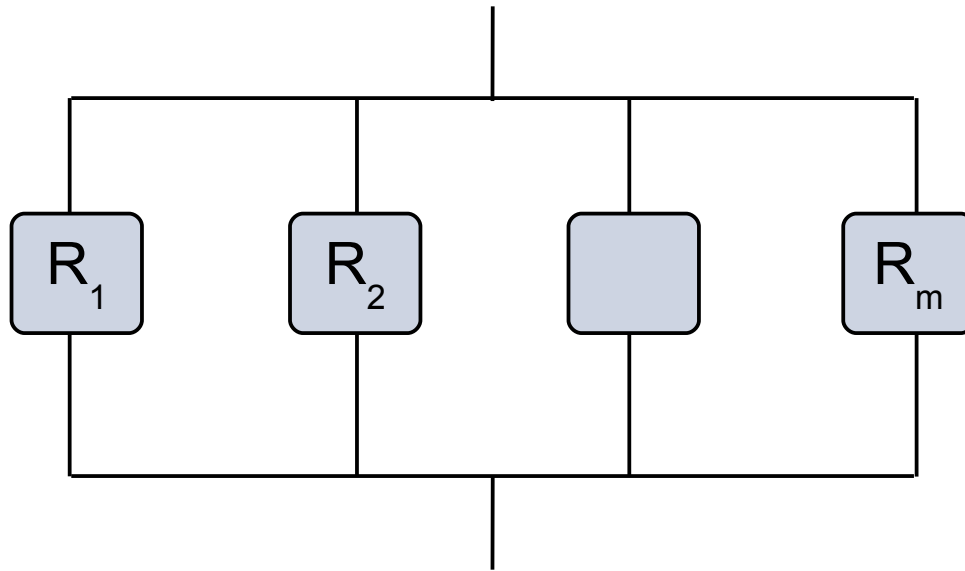

$$R_{whole} = 1 - \prod_{i=1}^m (1 - R_i)$$

- One component must work for the whole system to work.
- Each component must fail for the whole system to fail.

Serial-Parallel Systems

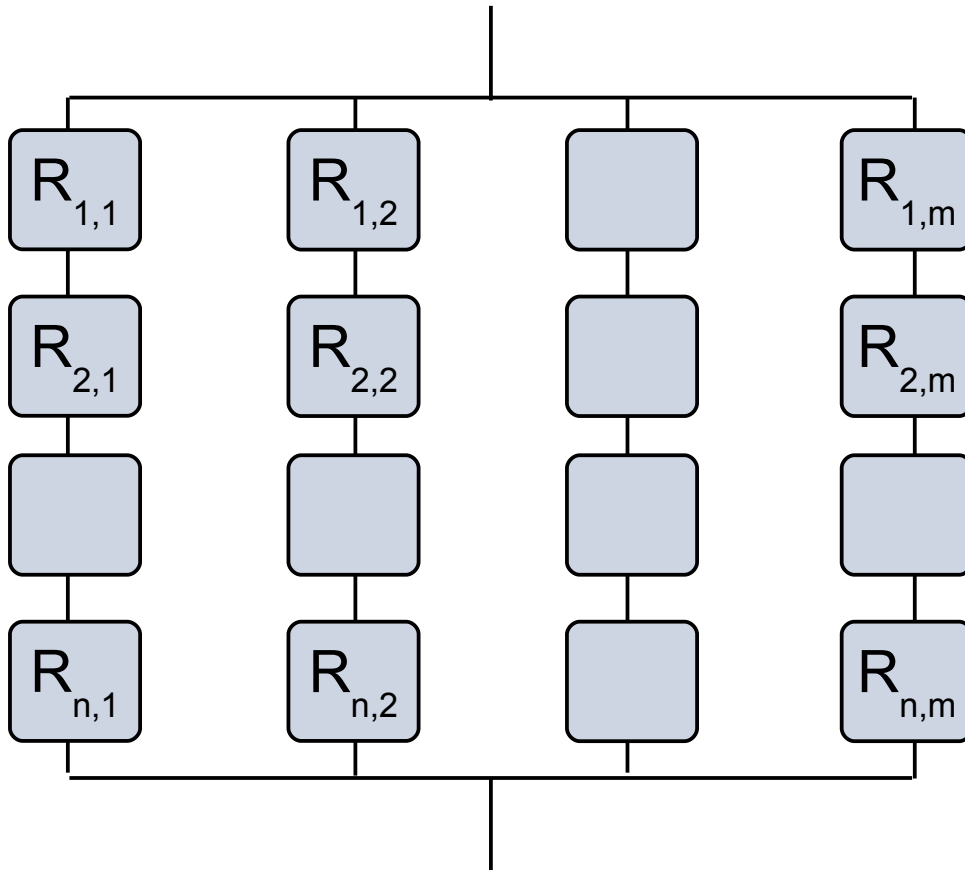

$$R_{whole} = 1 - \prod_{j=1}^m \left(1 - \prod_{i=1}^n R_{i,j} \right)$$

Our Example

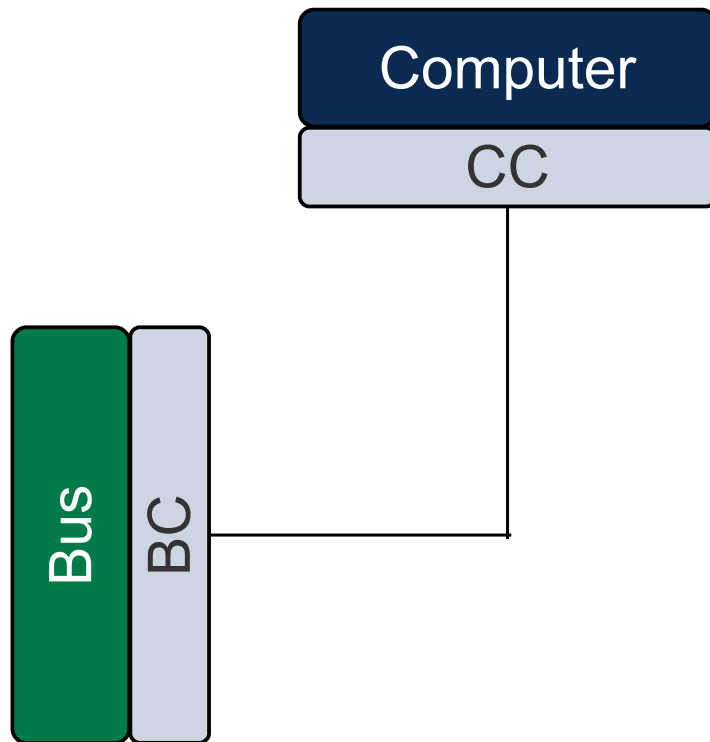

Fault Model

„Computer-Bus-Connector“
can fail such that Computer
and/or Bus also fail

therefore we model: conceptual
separation of connector into

- CC: Computer-Connector,
whose fault also breaks
the Computer
- BC: Bus-Connector, ...

Our Example

1 Buses
1 Computers

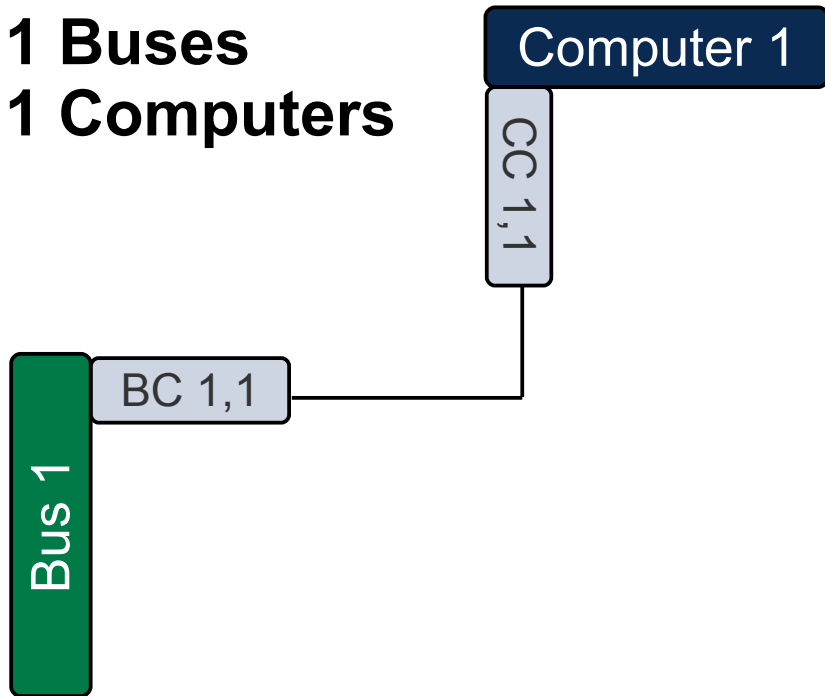

Our Example

1 Bus
2 Computers

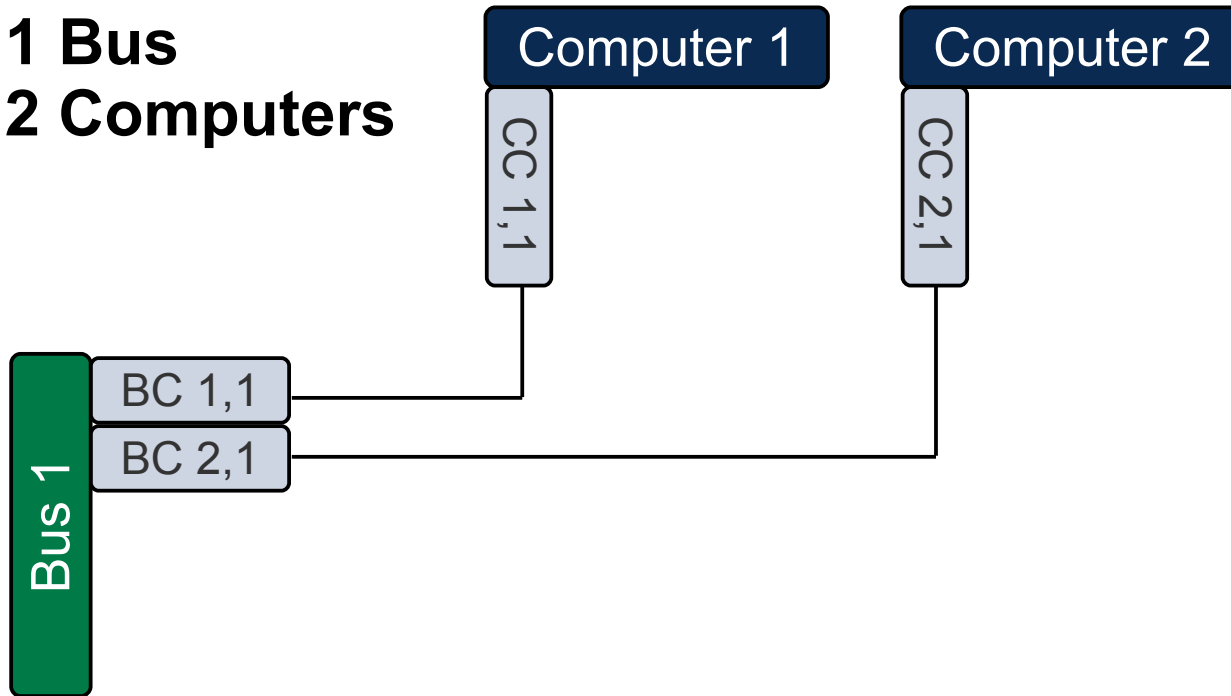

Our Example

1 Bus
N Computers

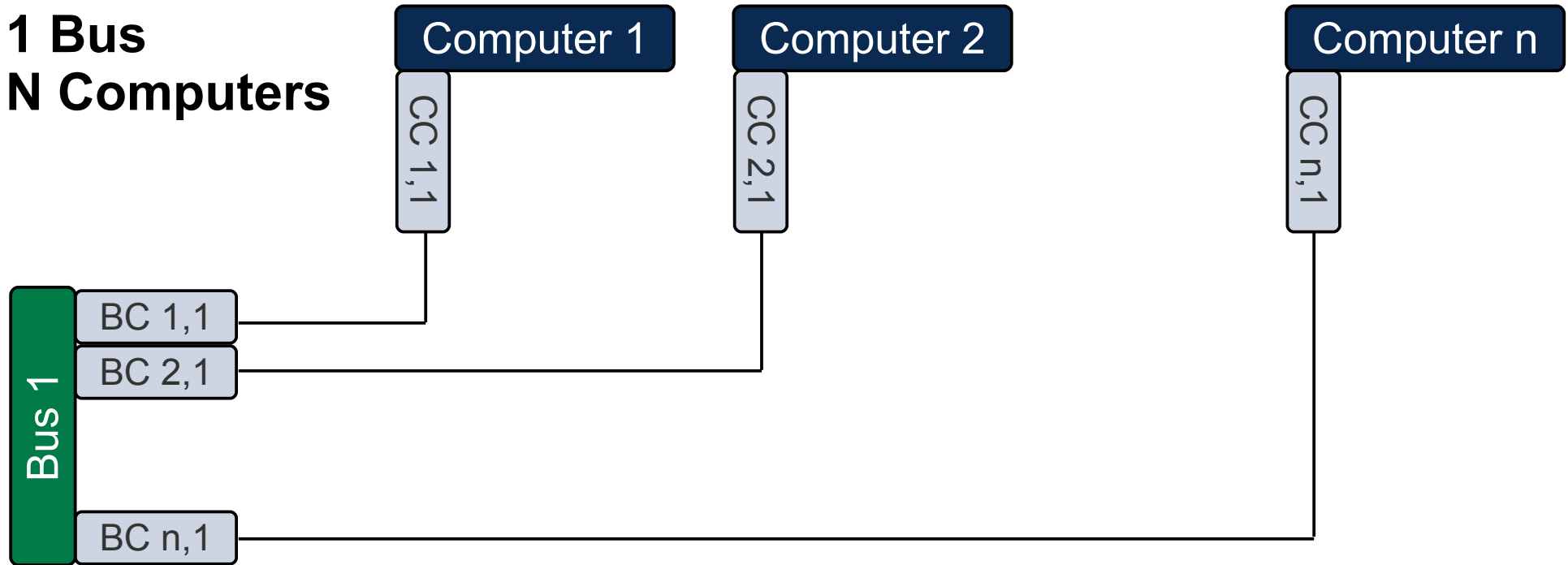

Our Example

M Buses
1 Computer

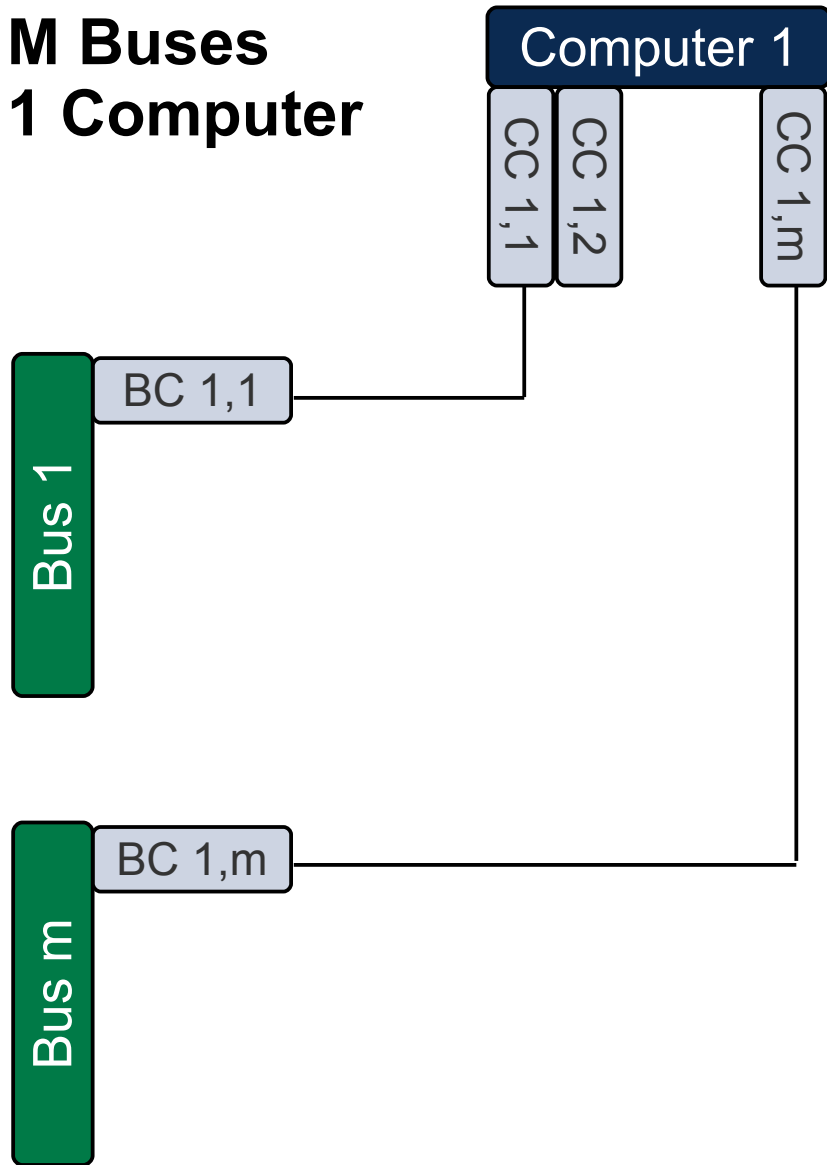

Our Example

M Buses
N Computers

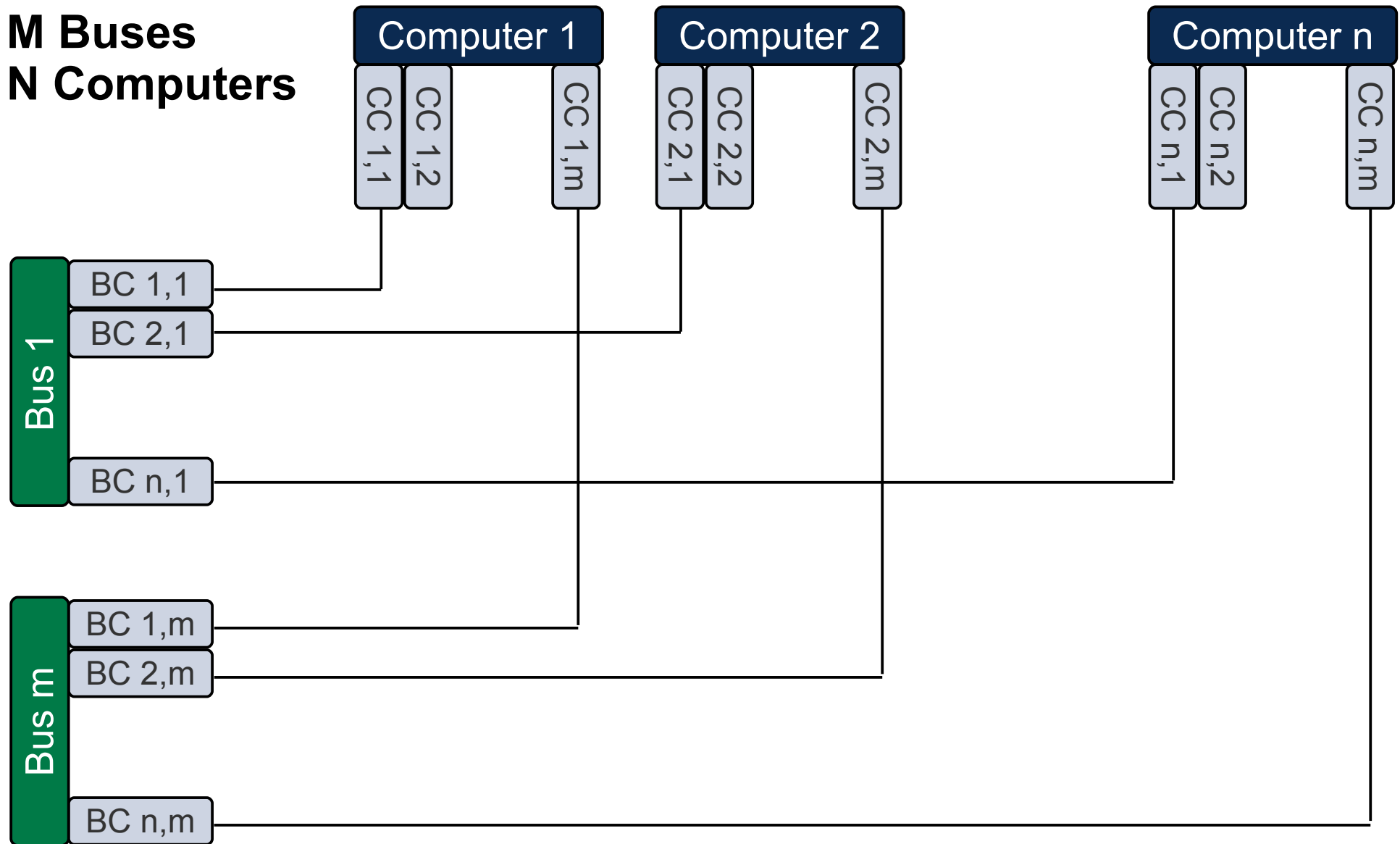

Model for m,n

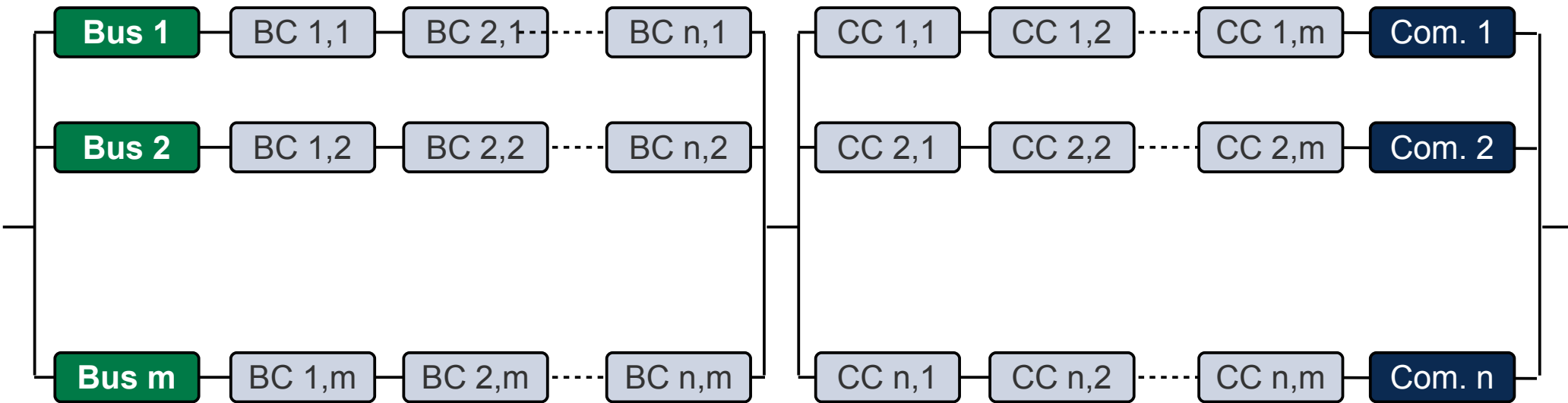

$$R_{whole}(n, m) = \left(1 - \left(1 - R_{Bus} \cdot R_{BC}^n\right)^m\right) \cdot \left(1 - \left(1 - R_{Computer} \cdot R_{CC}^m\right)^n\right)$$

then: $R_{CC}, R_{BC} < 1$: $\lim_{n, m \rightarrow \infty} R(n, m) = ??$

Limits(mathematical) of Reliability, Variant 2

- System built of Synapses (John von Neumann, 1956)
- Computation and Fault Model:
 - Synapses deliver „0“ or „1“
 - Synapses deliver with $R > 0,5$:
 - with probability R correct result
 - with $(1-R)$ wrong result
- Then we can build systems that deliver correct result for any (arbitrary high) probability R

Report here: cum grano salis!!

Two Army Problem (Coordinated Attack)

- p,q processes
 - communicate using messages
 - messages can get lost
 - no upper time for message delivery known
 - do not crash, do not cheat
- p,q to agree on action (e.g. attack, retreat, ...)
- how many messages needed ?
- first mentioned: Jim Gray 1978

Two Army Problem (Coordinated Attack)

- Result: there is no protocol with finite messages
- Prove:
 - by contradiction
 - assume there are finites protocols ($m_{p \rightarrow q}, m_{q \rightarrow p}$)*
 - choose the shortest protocol MP,
 - last message MX: $\underline{m}_{p \rightarrow q}$ or $\underline{m}_{q \rightarrow p}$
 - MX can get lost
 - \Rightarrow must not be relied upon \Rightarrow can be omitted
 - \Rightarrow MP not the shortest protocol.
 - \Rightarrow no finite protocol

Byzantine Agreement

- n processes, f traitors, $n-f$ loyal
 - communicate by reliable and timely messages
 - (synchronous messages)
 - traitors lie, also cheat on forwarding messages
 - try to confuse loyal
- Goal:
 - loyal try to agree on action (attack, retreat)
 - more specific:
 - one process is commander
 - if commander is loyal and gives an order, loyal follow the order otherwise loyal agree on arbitrary action

3 Processes: 1 traitor, 2 loyals

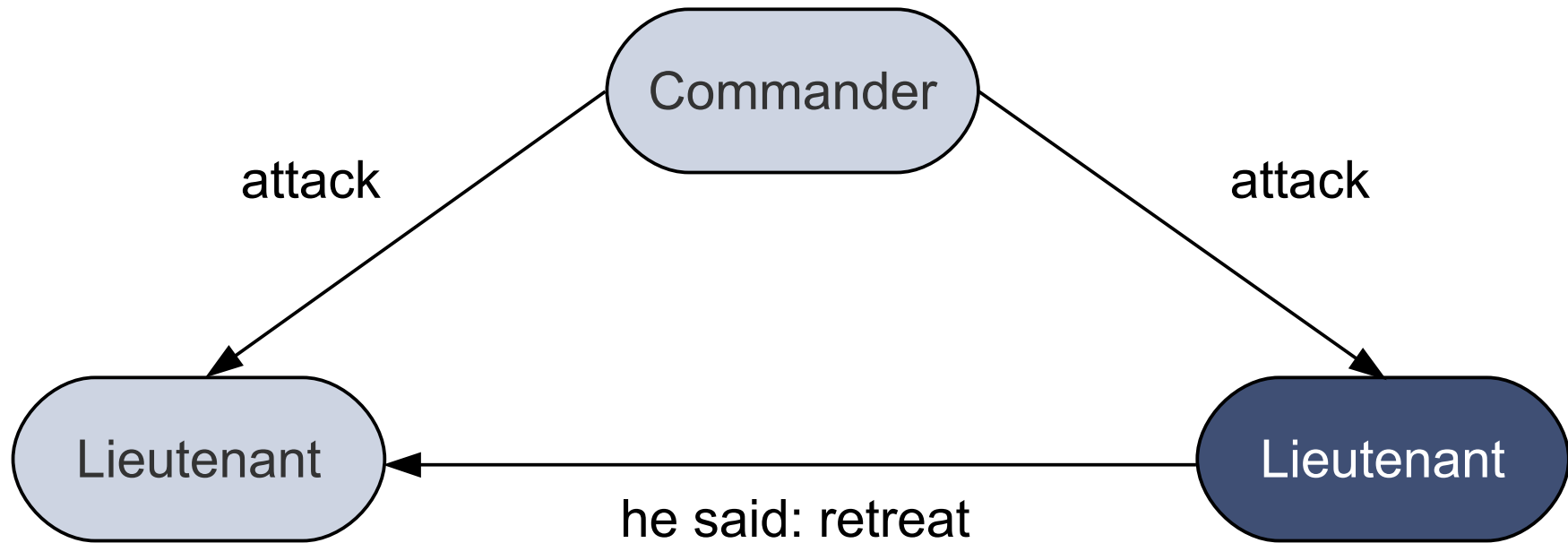

3 Processes: 1 traitor, 2 loyals

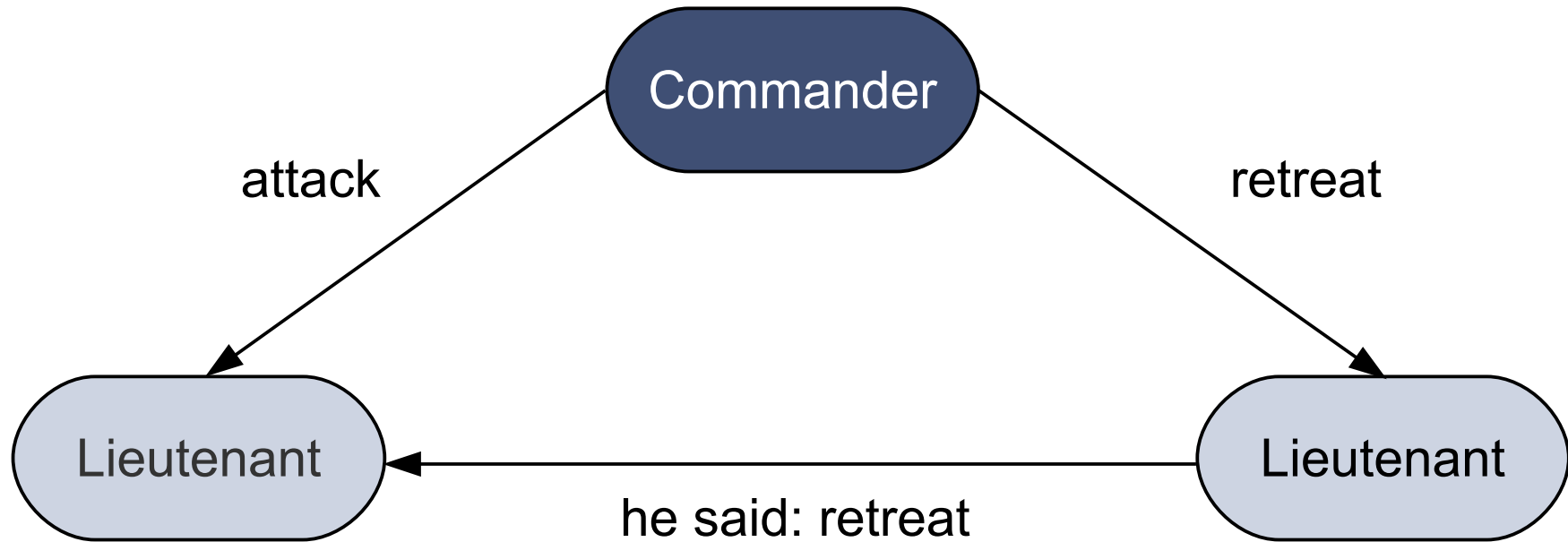

- 3 processes not sufficient to tolerate 1 traitor

4 Processes

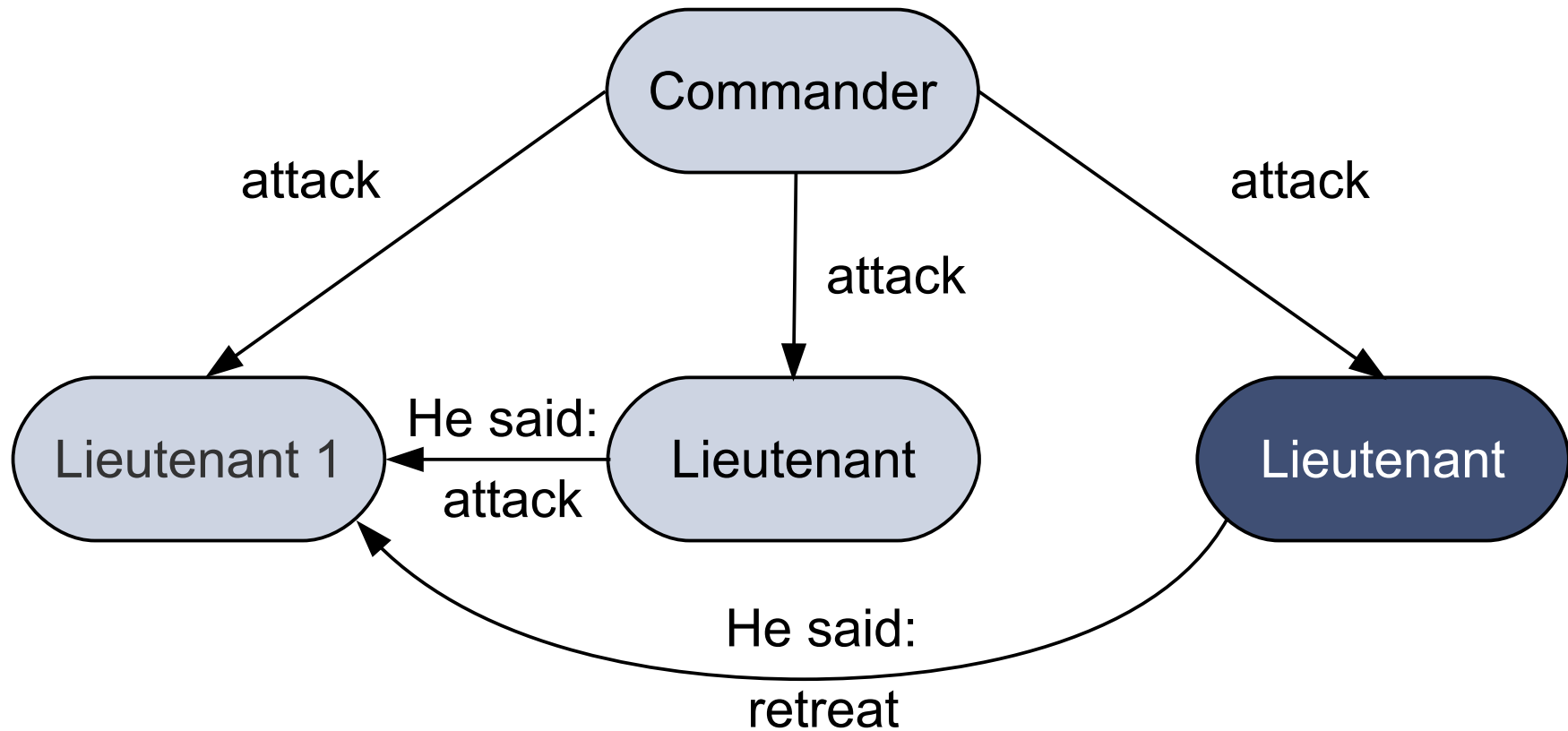

4 Processes

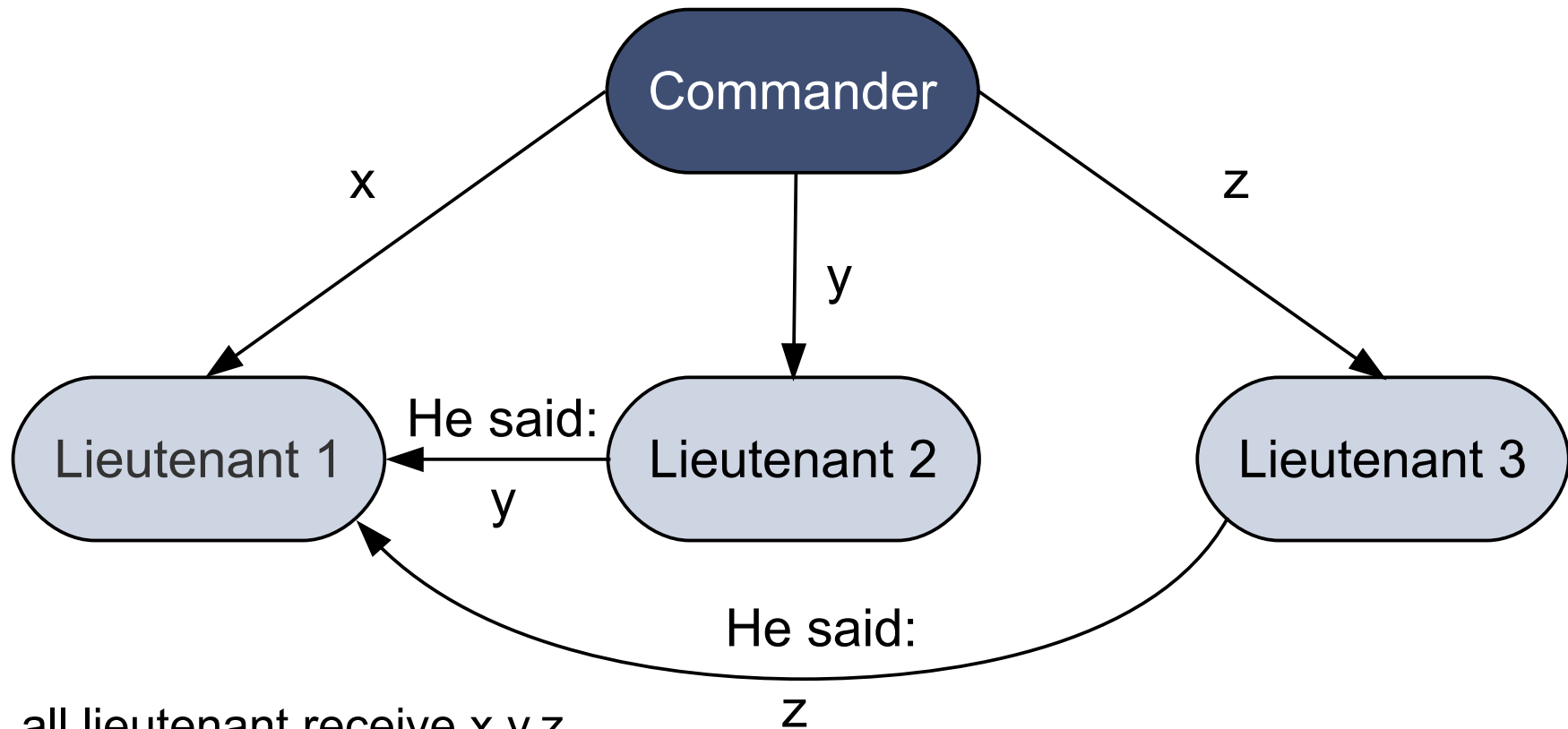

- all lieutenant receive x,y,z
- can decide
- General result: $3f + 1$ processes needed to tolerate f traitors

To take away

- modeling is very powerful
- extreme care needed to do it correctly