

Security

„Ausgewählte Betriebssysteme“
Institut Betriebssysteme
Fakultät Informatik

Outline

- Security Ratings
- Security System Components
- Logon
- Object (File) Access
- Impersonation
- Auditing

Security Ratings

- National Computer Security Center (NCSC) part of US Department of Defense (DoD)
- Defined 1983 DoD's Trusted Computer System Evaluation Criteria (TCSEC)
- TCSEC commonly referred to as "Orange Book"
- 1996 US, UK, GER, F, CA, NED developed Common Criteria for Information Technology Security Evaluation (CCITSE)
- CCITSE commonly referred to as "Common Criteria"

TCSEC Rating Levels

Rating	Description
A1	Verified Design
B3	Security Domains
B2	Structured Protection
B1	Labeled Security Protection
C2	Controlled Access Protection
C1	Discretionary Access Protection (obsolete)
D	Minimal Protection

Key Requirements for C2

- Secure Logon Facility:
 - Users can be uniquely identified and
 - Access granted only after identification
- Discretionary Access Control:
 - Owner of resource determines access to resource
- Security Auditing:
 - Detect and record security related events
 - Detect and record attempt to create, access or delete system resources
- Object reuse protection:
 - Prevent users from seeing data of other users

Met B-Level Requirements

- Trusted Path Functionality:
 - Prevent interception of user names and passwords (SAS)
- Trusted Facility Management:
 - Requires support for separate account roles (Administrator, Backup, Standard user, ...)

Outline

- Security Ratings
- Security System Components
- Logon
- Object (File) Access
- Impersonation
- Auditing

Security System Components

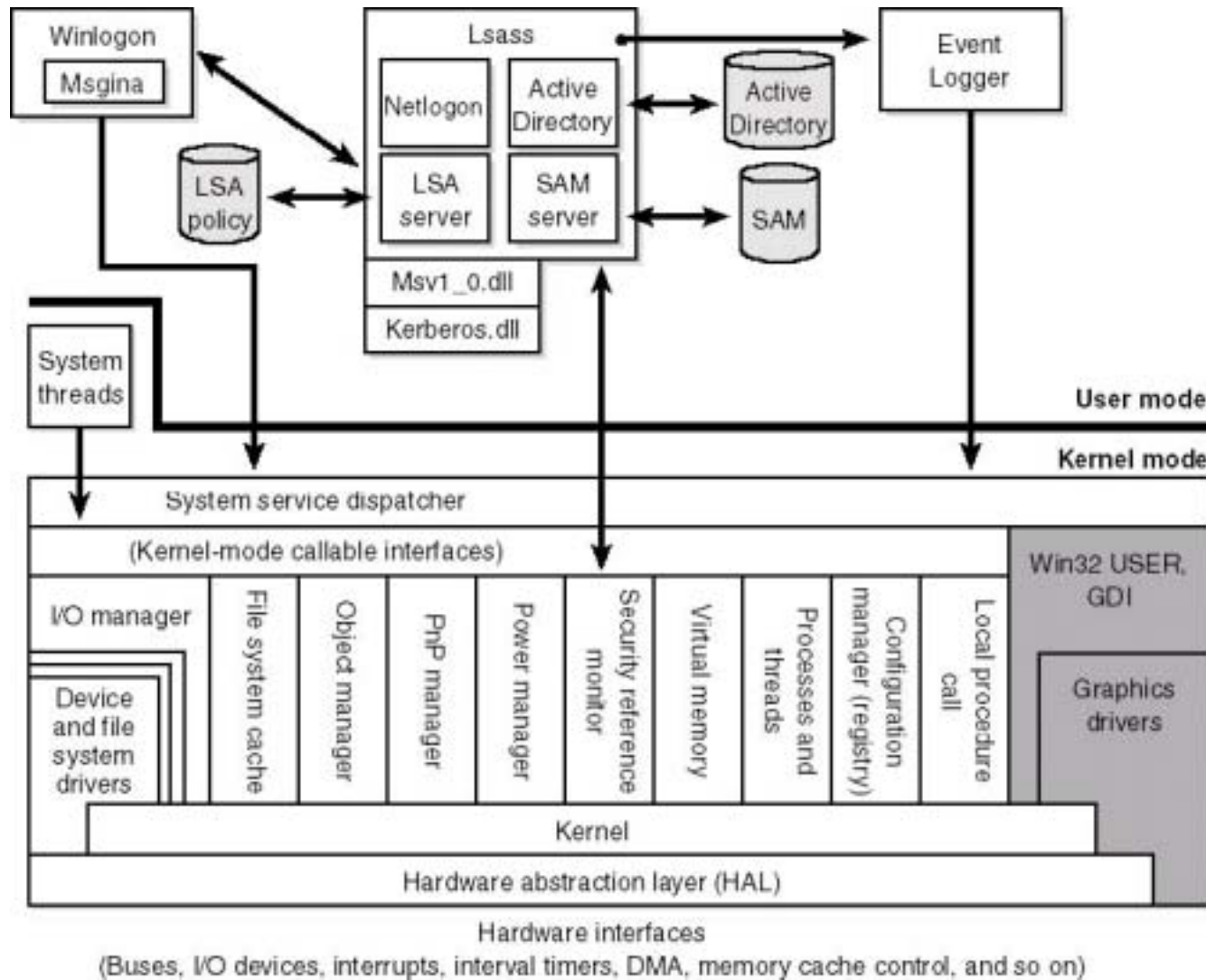

Picture © Mark Russinovich & David Solomon (used with permission of authors)

Security System Components (2)

- Security Reference Monitor (SRM)
 - Runs in kernel mode
 - Performs security checks on objects
 - Manipulates privileges
 - Generates security audit messages
- Local Security Authority Subsystem (Lsass):
 - Responsible for local system security policy
 - User authentication
 - Send security audit messages to event log
 - Most of it implemented in LSA service (Lsasrv.dll)

Security System Components (3)

- Lsass Policy Database
 - Contains local system security policy settings
 - Stored in registry under HKLM\SECURITY
 - Contains trusted domains, who has access and how (local, network, service), who has what privileges
 - Contains secrets, such as logon information and Win32 service user logons
- Security Accounts Manager (SAM)
 - Manages database containing user names and groups

Security System Components (4)

- SAM database
 - Contains local users and groups along with passwords and other attributes
 - Stored in HKLM\SAM
- Active Directory
 - Manages database that stores information about objects in a domain (users, groups, computers, ...)
- Authentication Packages
 - DLL implementing authentication policy
 - Responsible for checking match of username and password

Security System Components (5)

- Logon Process
 - Responds to secure attention sequence (SAS)
 - Manages interactive logon sessions
- Graphical Identification and Authentication (GINA)
 - Used to obtain username and password (or similar)
- Netlogon
 - Responds to network logon requests
- Kernel Security Device Driver (KSecDD)
 - Provides mechanism for kernel components to communicate with Lsass

Communication Kernel – User

- During boot Lsass communicates with SRM using ports (both listen on ports)
- Establish shared memory region and stop listening on port (port is connected)

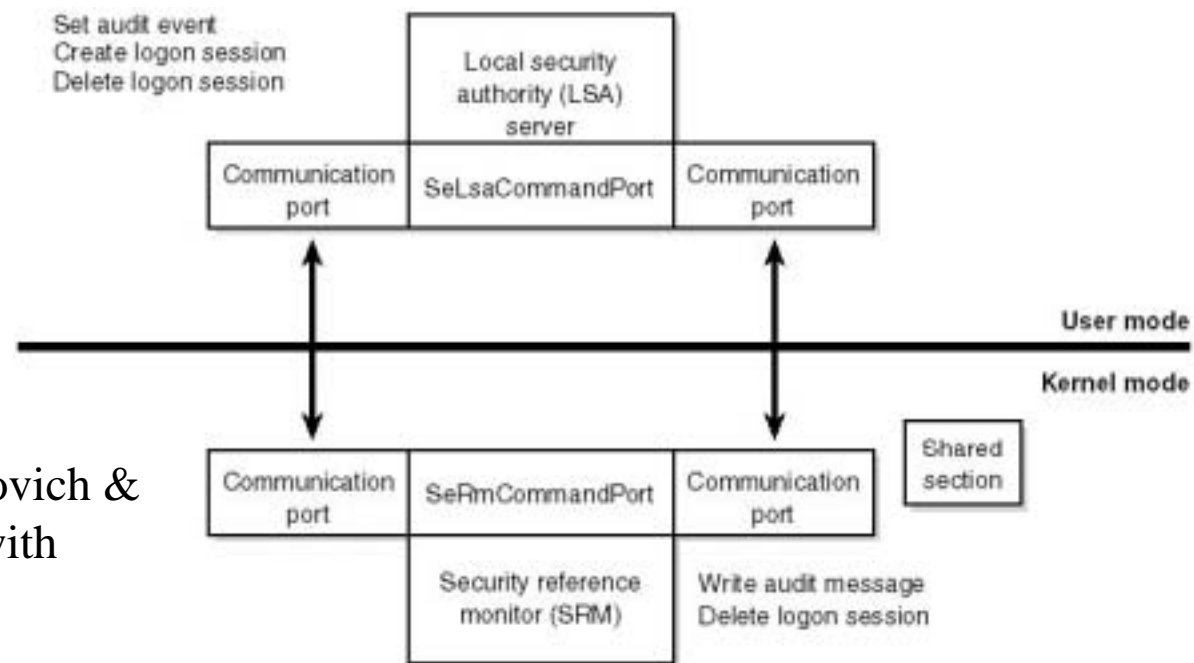

Picture © Mark Russinovich & David Solomon (used with permission of authors)

Outline

- Security Ratings
- Security System Components
- Logon
- Object (File) Access
- Impersonation
- Auditing

Winlogon Initialization

1. Create and open interactive window station to represent keyboard, mouse, and monitor
 - Create security descriptor for itself, thus allowing only itself access
2. Creates and opens desktops
 - Application desktop (winlogon + user)
 - Winlogon desktop (only winlogon)
 - Screen saver desktop (winlogon + user)
 - SAS switches to winlogon desktop → brings up secure desktop

Winlogon Initialization (2)

3. Establish LPC connection to Lsass
4. Initialize and register window class structure for logon window (associate process with a window)
5. Register SAS with created window → that window's procedure is called
6. Register window → now winlogon is notified when user logs off or screen saver times out

Logon

- Winlogon process intercepts SAS
 - Can be CTRL+ALT+ENTF
 - Can be insertion of smart card into reader
- Requests GINA to obtain identification
- Calls Lsass to authentication user
- Call network providers (if any) to gather logon information
- Activates logon shell on behalf of user

Logon

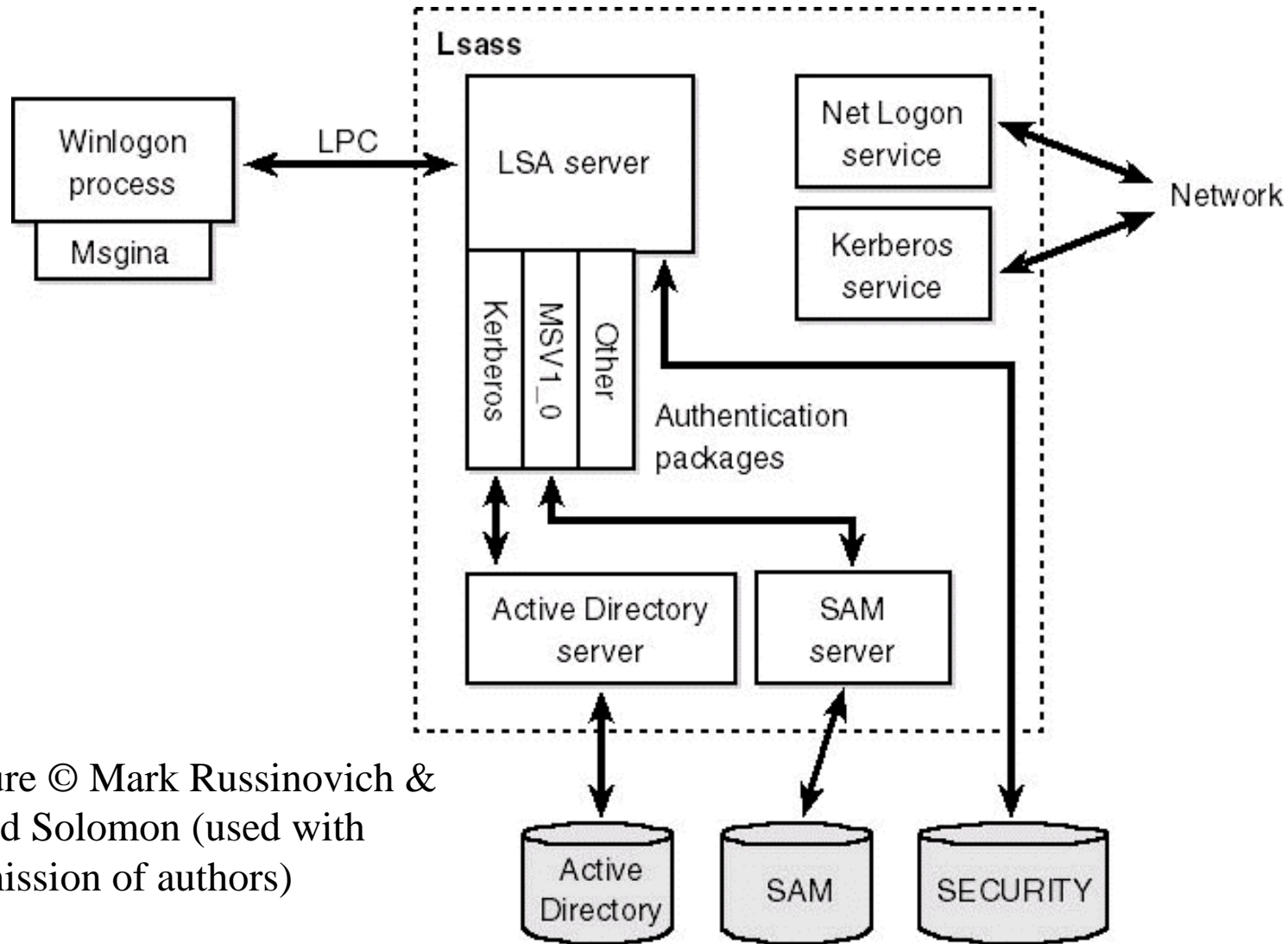

Picture © Mark Russinovich & David Solomon (used with permission of authors)

User Logon Steps

- Winlogon intercepts SAS
 - Creates unique group, which is passed to Lsass during authentication
 - Group attached to desktop
 - After authentication group is attached to logon process token
- Prevents other user logging in on same account to write to first user's desktop

Authentication

- With username and password each registered authentication package is called
- HKLM\SYSTEM\CurrentControlSet\Control\Lsa
- MSV1_0 used for local authentication
 - Username + hashed password sent to SAM
 - Returns password, groups, restrictions
- Kerberos used on computer belonging to a domain
 - Version 5, revision 6 for win2K
- Create locally unique identifier (LUID) for logon session and associate LUID with session
 - needed to create access token for user

After Authentication

- Lsass checks policy database for restrictions
- Lsass adds additional security IDs (everyone, interactive, ...) to access token
- Access token passed to executive to be created
- Executive returns handle, which is handed to winlogon
- Auditing longon
- Check HKLM\Software\Microsoft\WindowsNT\Current Version\Winlogon\Userinit for executables
- Userinit.exe loads profile and creates process for HKLM\Software\Microsoft\WindowsNT\Current Version\Winlogon\Shell

Outline

- Security Ratings
- Security System Components
- Logon
- Object (File) Access
- Impersonation
- Auditing

Access Checks

$f(\text{thread, desired access, object}) \rightarrow \text{yes/no}$

- Thread's security identity is access token of process or impersonation (see below)
- User specifies desired access to object
→ access mask stored in handle
- Object's security settings and thread's security identity locked during check
→ no modification possible

Security Identifiers

- Instead of using names for subjects, a security identifier (SID) is used

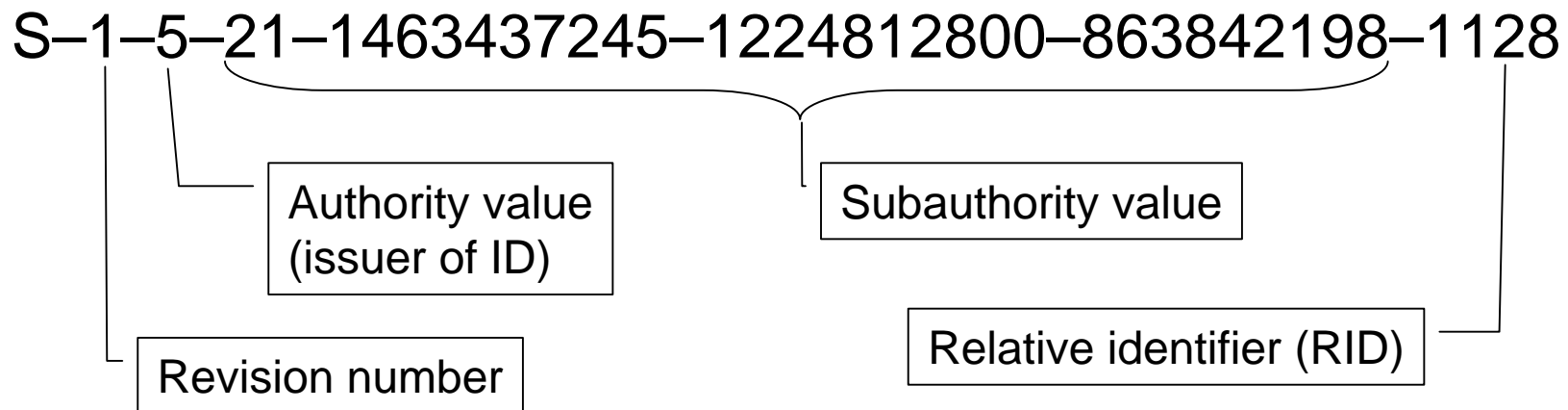

- SID for: users, local and domain groups, computer, domains, domain members

Security Identifiers (2)

- RID of 1000 and bigger for users and groups (see getsid.exe)
- Built-in SIDs:

SID	Group	Use
S-1-1-0	Everyone	All users
S-1-2-0	Local	User who log in locally
S-1-3-0	Creator Owner ID	To be replaced by SID of creator
S-1-3-1	Creator Group ID	To be replaced by primary group SID of creator

Tokens

- To identify security context of a thread tokens are used
- Initial token created during logon
- All other programs inherit copy of that token
- Can create token with login information
- User SID and Group SID used for authorization
- Also privileges

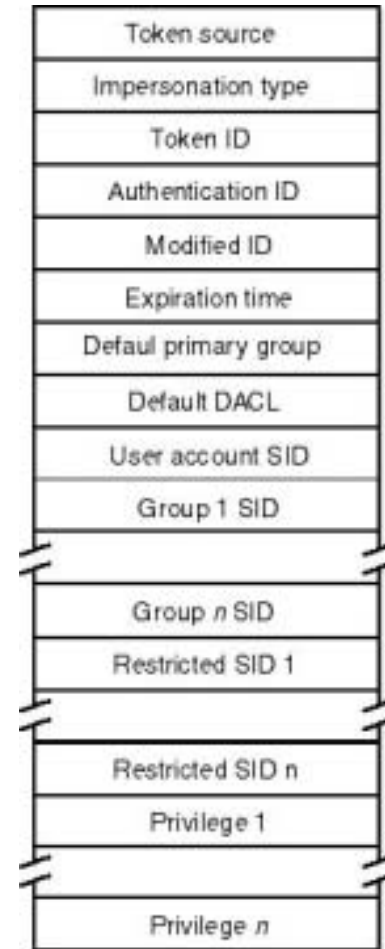

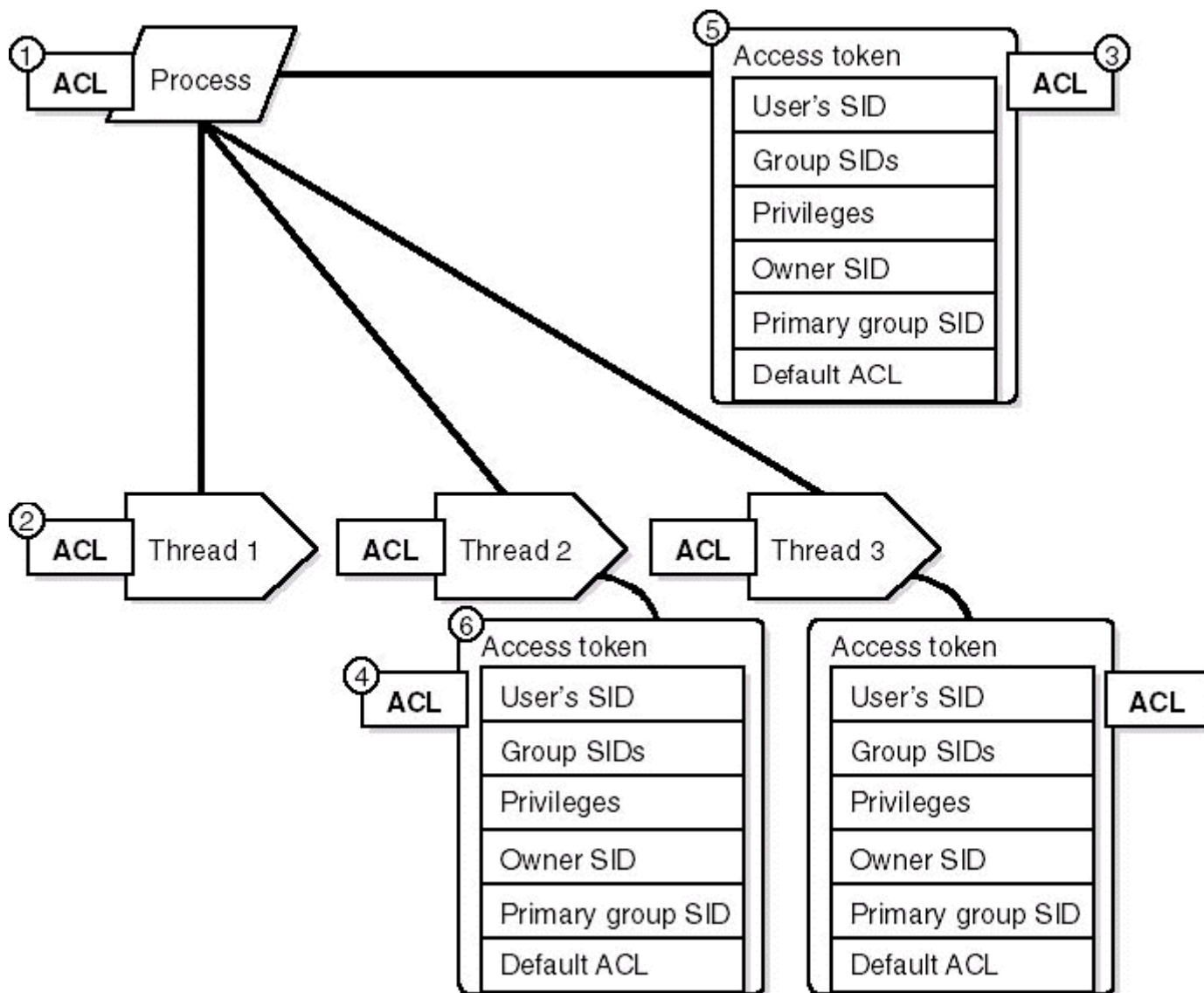

Picture © Mark Russinovich & David Solomon (used with permission of authors)

SIDs and Access Control

- Object's security information is *security descriptor*
 - Revision number
 - Flags (for instance inheritance)
 - Owner SID
 - Group SID (only used by POSIX)
 - Discretionary access-control list (DACL): who has what access
 - System access-control list (SACL): what should be audited

Access Control List

- Header + list of access control entries (ACE)
- In DACL an ACE contains SID and access mask
- In SACL an ACE contains operations and user performing operation to be audited

DACL ACEs

- Four types
- Access allowed, access denied:
 - Grant or deny access to user
- Allowed-object, denied-object:
 - Used within Active Directory only
 - Contain GUID specifying object or subobject to which ACE applies
- If no DACL is present, everyone has access
- If empty DACL is present, no user has access

File Object and its DACL

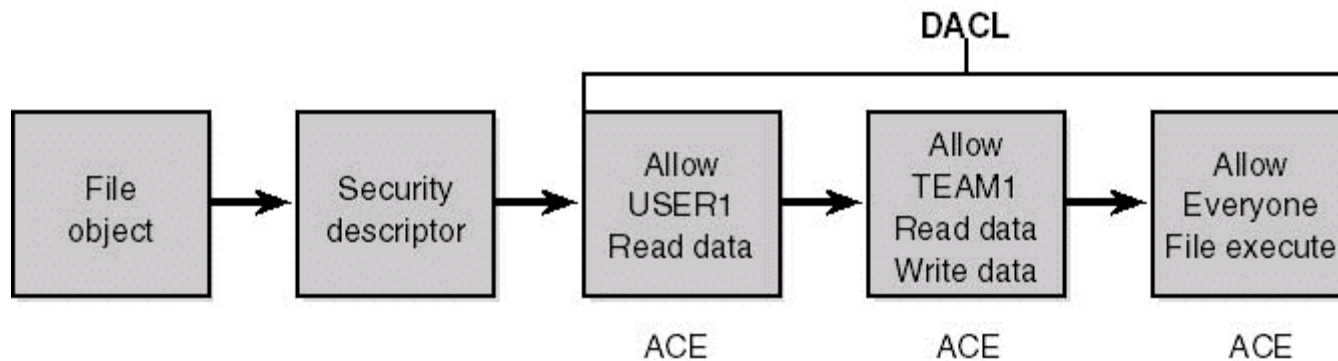

Picture © Mark Russinovich & David Solomon (used with permission of authors)

Determine Access

- Two algorithms
 - One to determine maximum access allowed
 - One to determine whether specific access is allowed

Maximum Allowed Access

1. If no DACL → all access granted
2. If caller has take-ownership privilege, system grants write-owner before DACL parsing
3. If caller is owner: read-control and write-DACL are granted
4. For each access-denied ACE the ACE's access mask is removed from granted-access mask
5. For each access-granted ACE the ACE's access mask is added to granted-access mask if not removed previously

Check Access Rights

1. If object has no DACL → access granted
2. If caller has take-ownership → system grants write-owner
3. If owner → read-control and write-DACL granted
4. Each ACE is processed (see next slide)
5. If end of DACL is reached and some of requested rights are not granted → access denied
6. If restricted SIDs → rescan DACL for restrictions

ACE matching

- a. SID in ACE matches caller's SID
- b. ACE is access-allow and SID in ACE matches a caller SID which is not deny-only
- c. If SID in ACE matches restricted SID (6.)

→ If access-allowed ACE: ACE rights are granted;
if all requested rights are granted

→ access granted

→ If access-denied ACE: if requested access rights
match → access denied

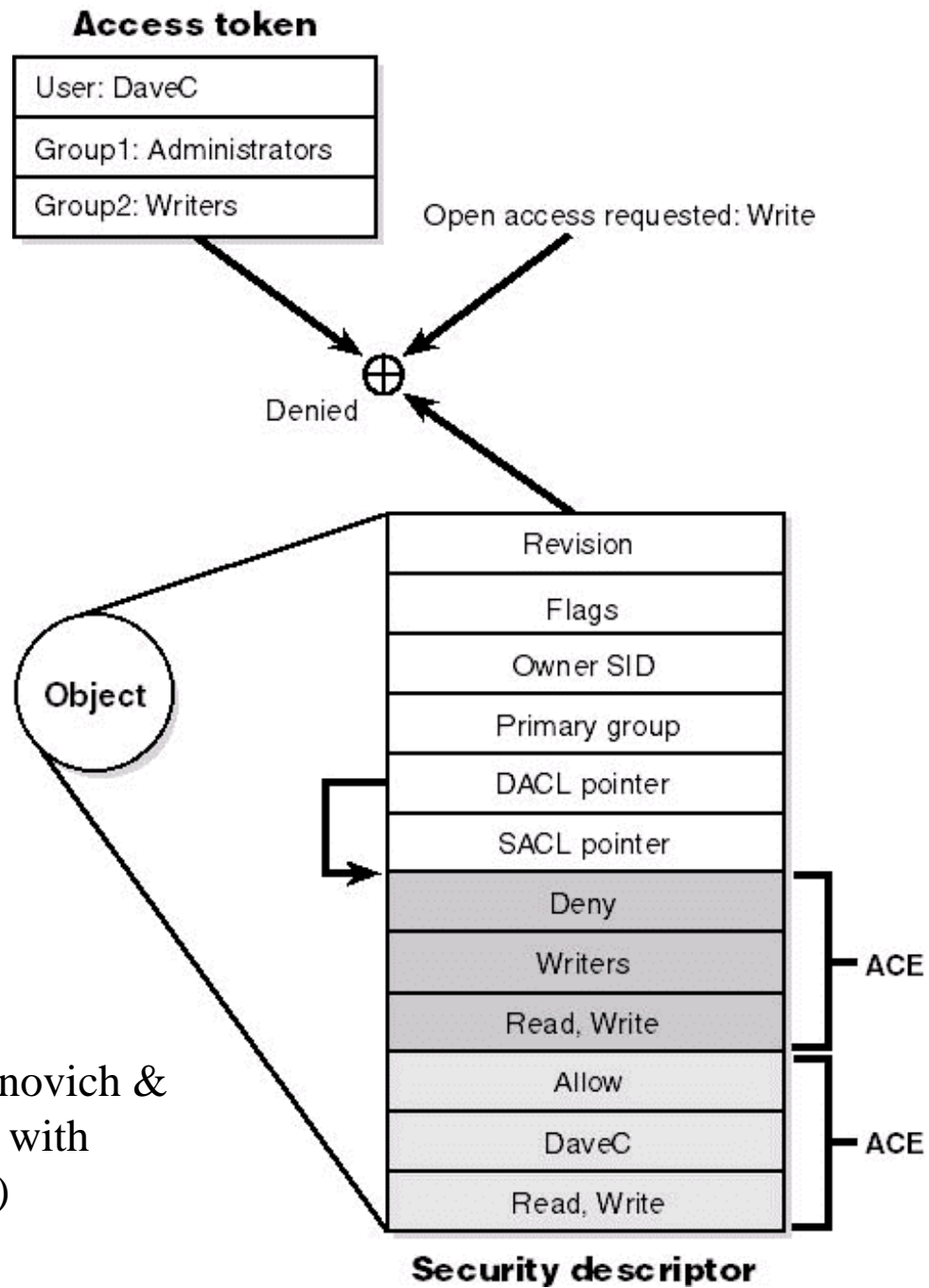

Picture © Mark Russinovich & David Solomon (used with permission of authors)

ACE Ordering

- Deny ACEs must precede allow ACEs
- Otherwise: if all requested rights are satisfied before they can be denied, the request is granted.

Outline

- Security Ratings
- Security System Components
- Logon
- Object (File) Access
- Impersonation
- Auditing

Impersonation

- Useful for servers acting on behalf of client
- Restricted to thread, but other threads have access to handles
- TCB contains entry for impersonation token
- After job is done, server reverts to original token
- Cannot execute entire program in context of a client
- Cannot access files or printers on network shares

Logging Users On

- Alternative to impersonation is logon of client
- *LogonUser* requires username, password, domain or computername, logon type
- Returns access token → used to run program as client
- Or: duplicate access token of client and use as parameter to *CreateProcessAsUser*
- Disadvantages: obtaining logon information from client

Misuse

- Impersonation only with consent of client
- Client can limit level of impersonation
 - SecurityAnonymous: server cannot impersonate nor identify client
 - SecurityIdentification: server cannot impersonate but identify the client
 - SecurityImpersonation: server can impersonate and identify client
 - SecurityDelegation: lets server impersonate client on local and remote systems

Outline

- Security Ratings
- Security System Components
- Logon
- Object (File) Access
- Impersonation
- Auditing

Security Auditing

- Object manager can create audit message as result of access check
- Win32 functions to generate audit messages (SeAuditPrivilege required)
- Kernel mode code can generate audit messages
- SRM sends messages to Lsass which adds additional information and writes to log

Flow of Auditing Records

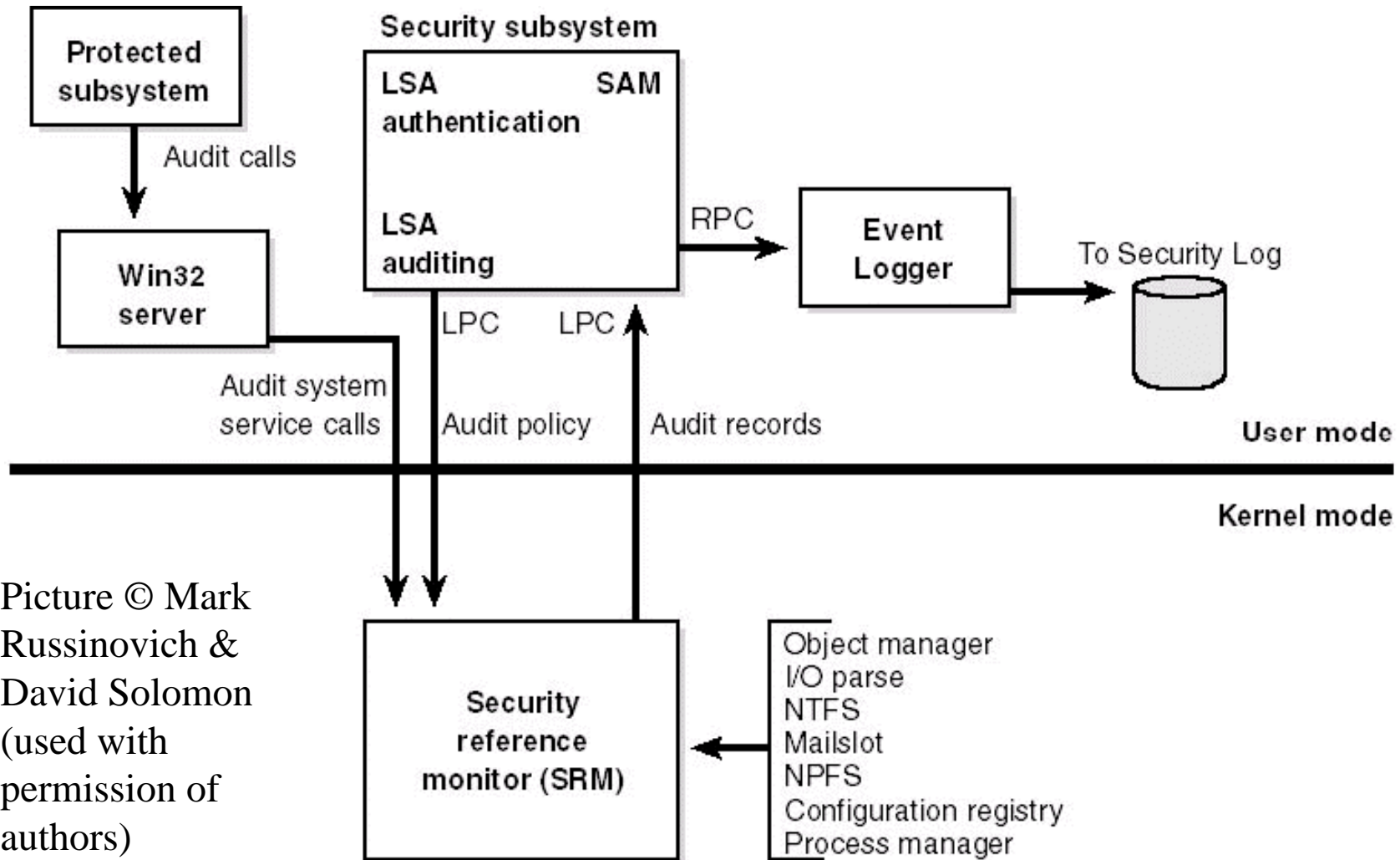

Picture © Mark
Rusinovich &
David Solomon
(used with
permission of
authors)